

# HF-C89 '6 C5 F8 – Схема внешних подключений 1

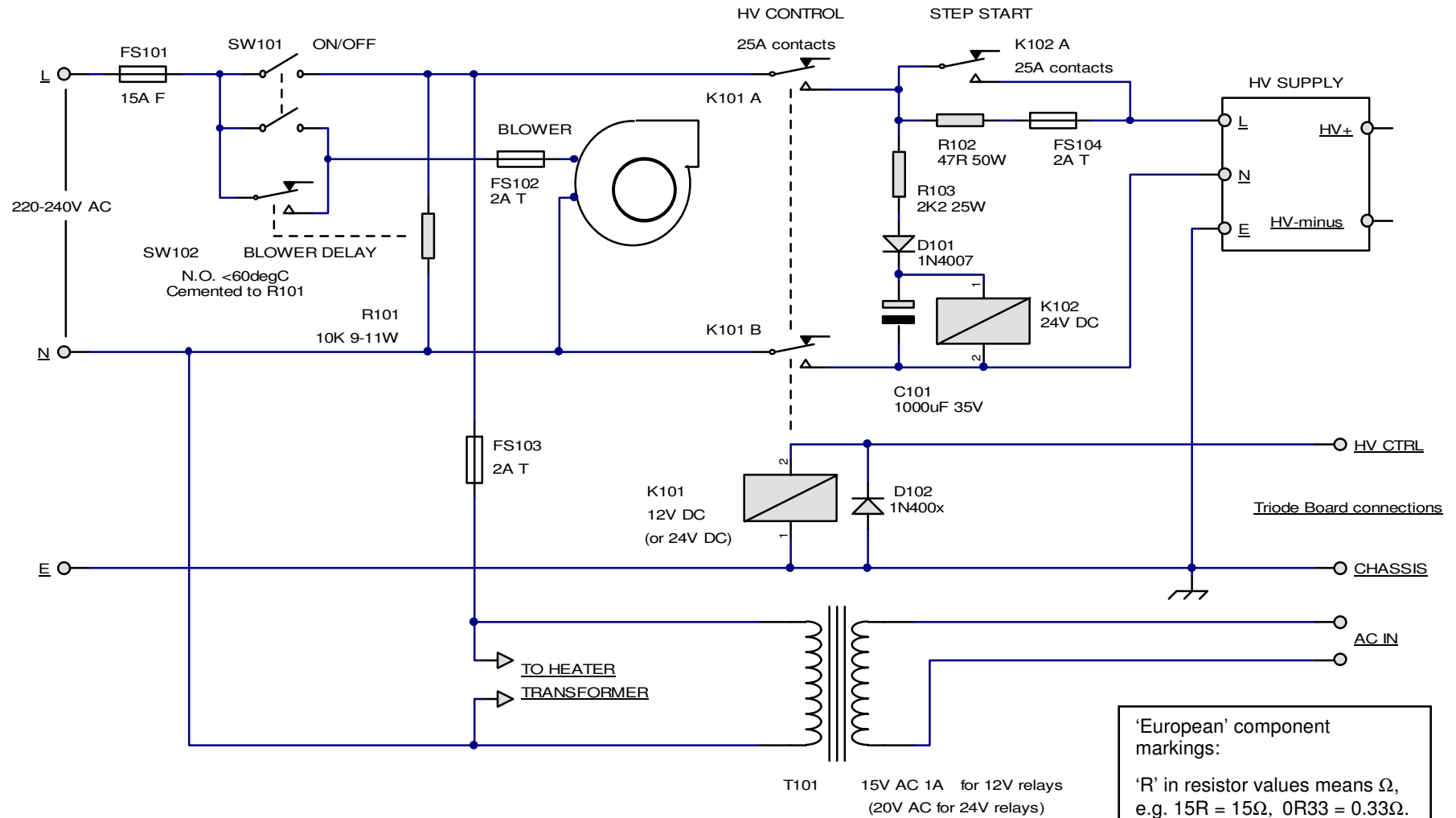

## HF-C89 '6 C5 F8 – Схема внешних подключений 2

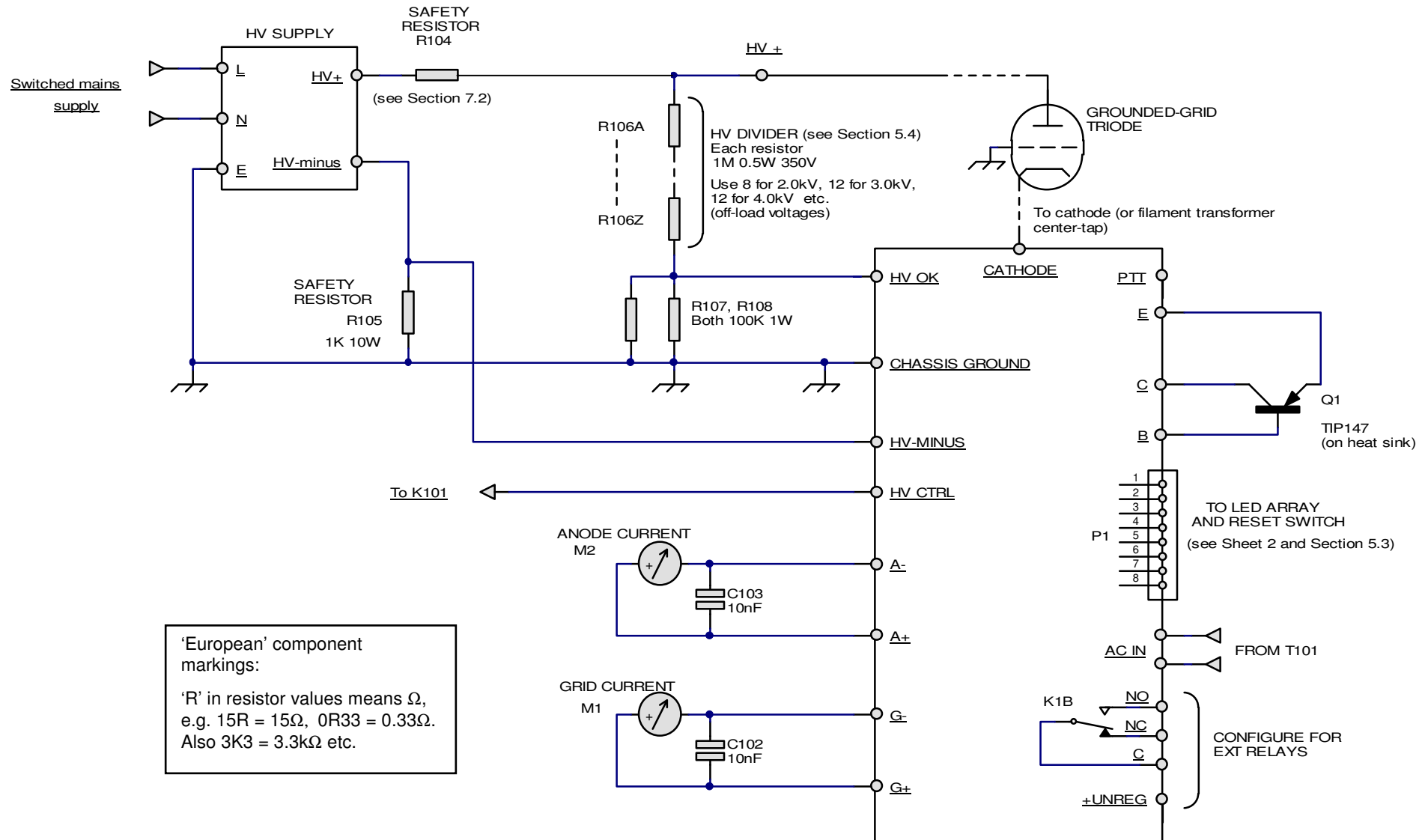

'European' component markings:  
'R' in resistor values means Ω,  
e.g. 15R = 15Ω, 0R33 = 0.33Ω.  
Also 3K3 = 3.3kΩ etc.

# Схема TRIODE BOARD – страница 1

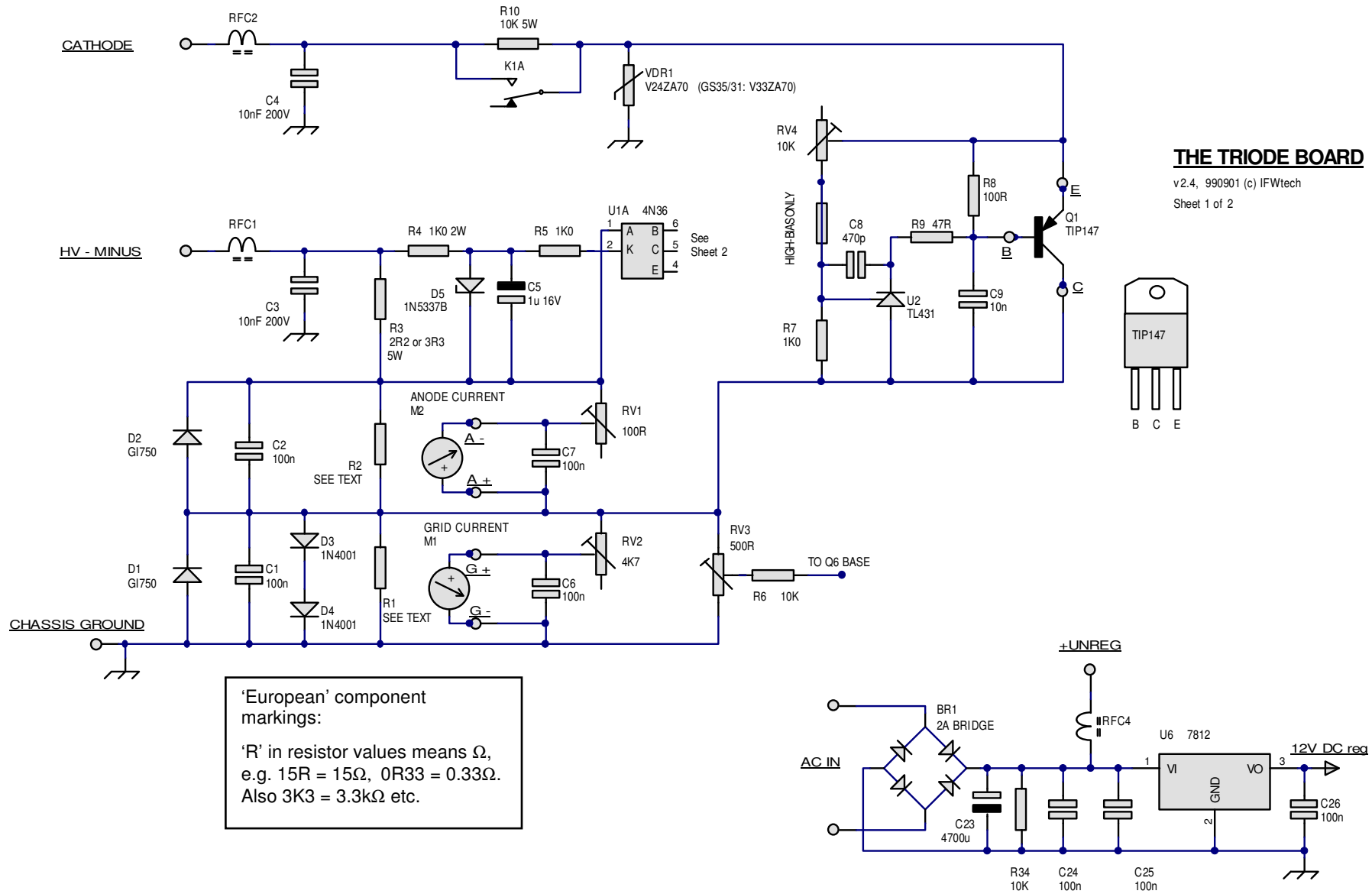

# Схема TRIODE BOARD – страница 2

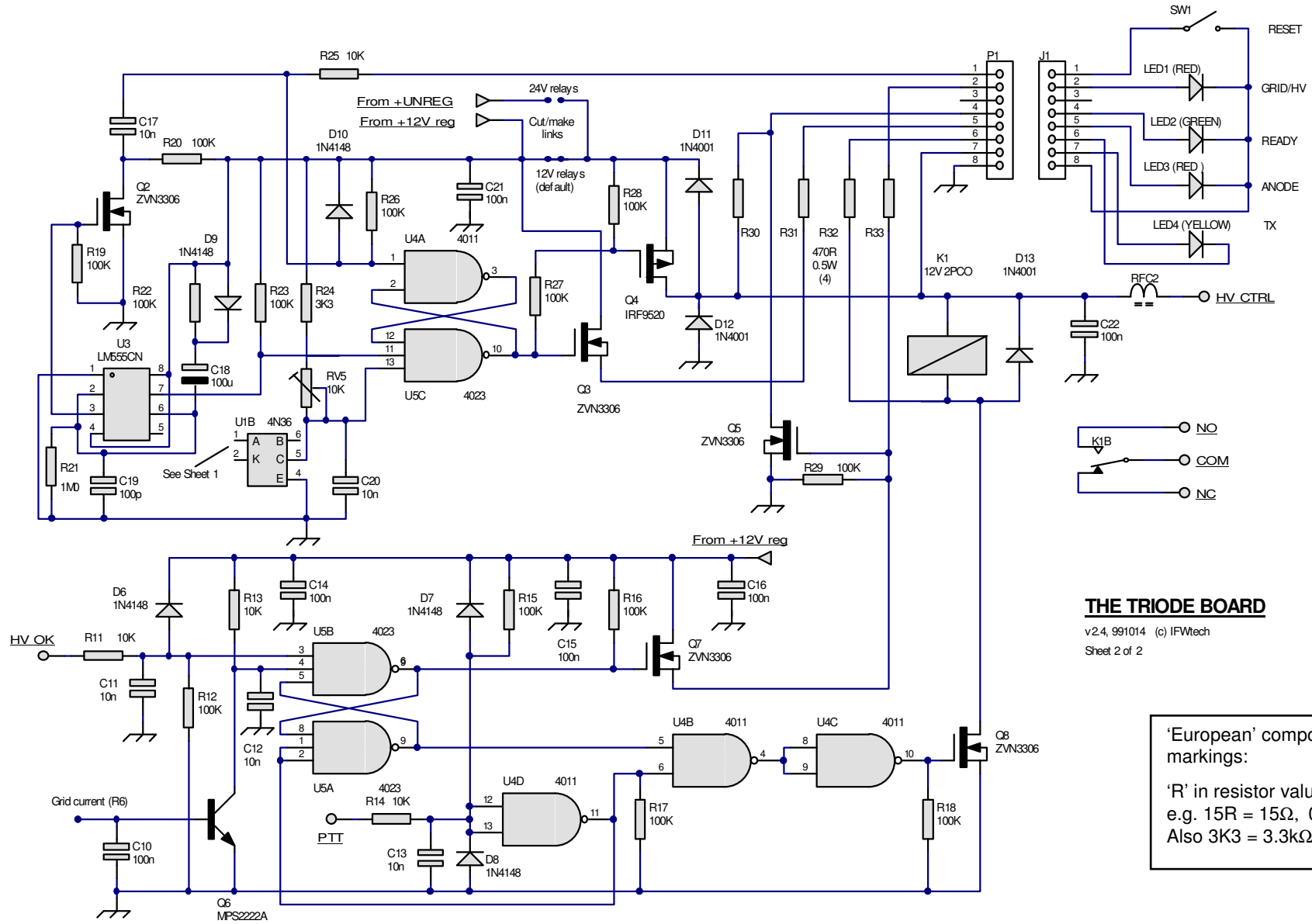

## THE TRIODE BOARD

v2.4, 991014 (c) IFWtech  
Sheet 2 of 2

'European' component markings:  
'R' in resistor values means Ω,  
e.g. 15R = 15Ω, 0R33 = 0.33Ω.  
Also 3K3 = 3.3kΩ etc.